

DAN-TRANSDUCER ApS

DOUBLE SHEAR BEAM
CAPACITY: 20.000 Kg.

MODEL DT 3757

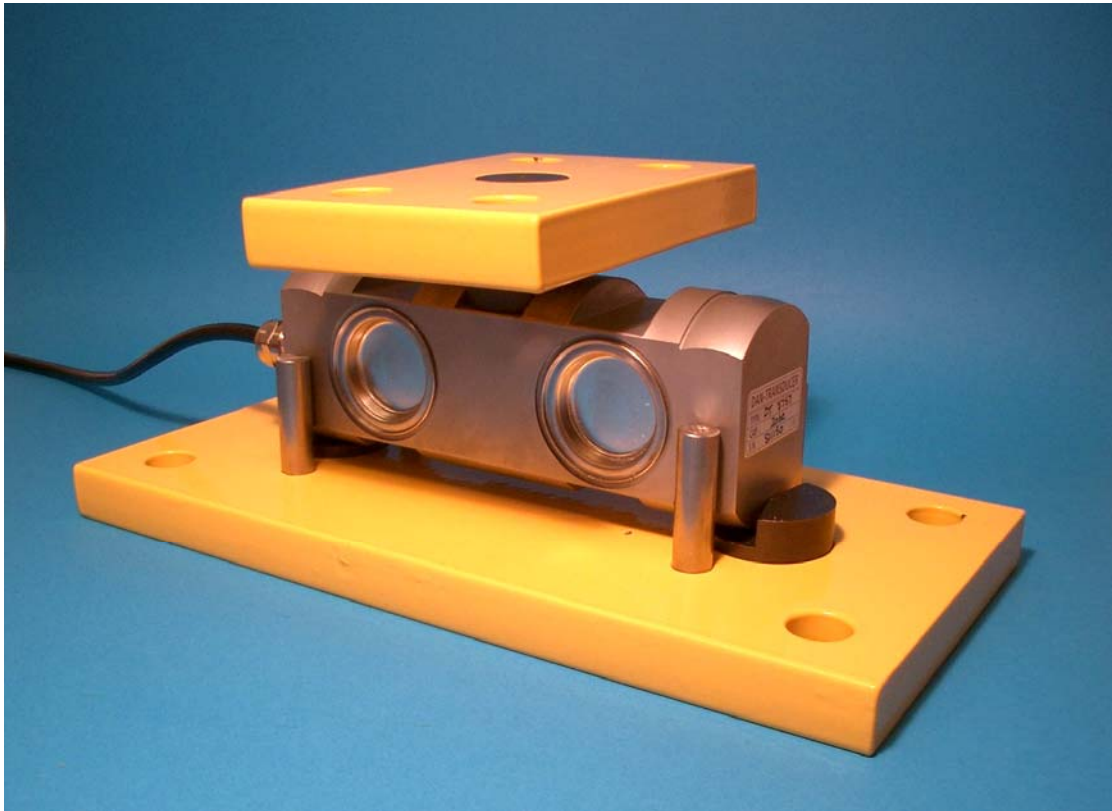

MODEL 3757

TRUCK SCALE LOAD CELL IN STAINLESS STEEL WITH PAINTED STEEL MOUNTINGS

- FAST AND EASY INSTALLATION WITHOUT ANY SPECIEL TOOLS
- LOW COST LOAD CELL IN VERY LOW EXECUTION FOR ALL KINDS OF BRIDGES
- EASY TO REPLACE WITHOUT ANY TOOLS
- STAINLESS STEEL QUALITY LOAD CELL TOTALLY WELDED TO IP 68
- ACCURACY BETTER THAN 3000 DIVISIONS
- EASY TO HANDLE FOR DO IT YOURSELF PEOPLE
- THE LOAD CELLS OBSTAINS ALL SIDEFORCES, THEREFORE NO STOPS

DAN-TRANSDUCER ApS

Fiskerengen 5, DK-3250 Gilleleje - Phone: +45 48 22 44 02 - Fax: +45 48 22 44 06
www.dan-transducer.com, E-mail: info@dan-transducer.com

DAN-TRANSDUCER ApS

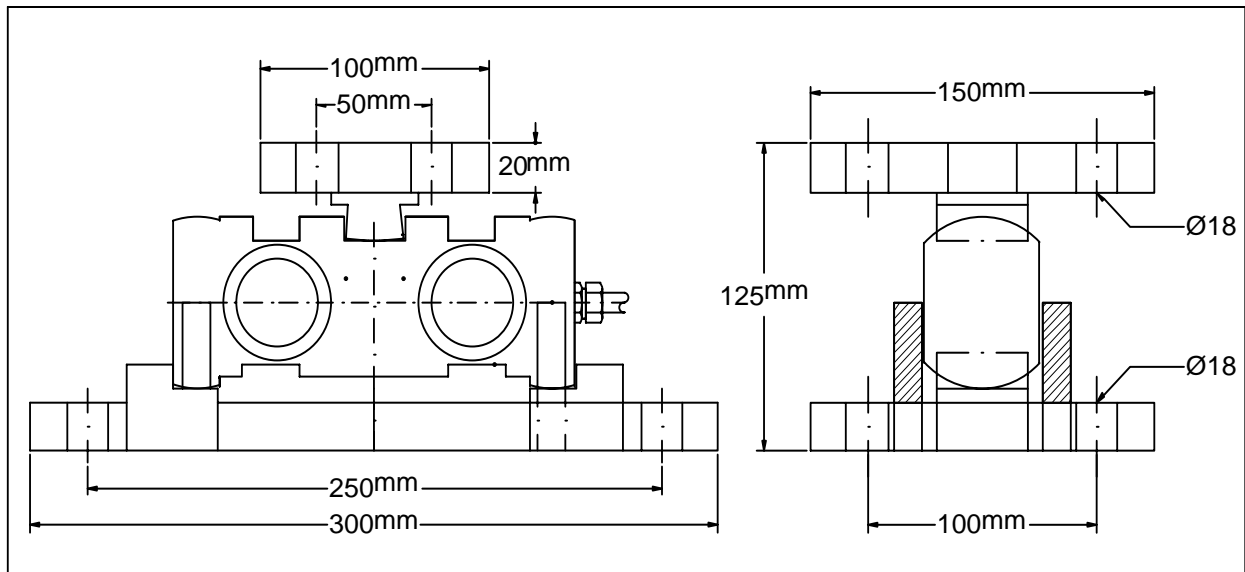

SPECIFICATIONS

	UNITS	DATA
Standard Load Ranges	Kg	20.000 (30.000)
Full Load Output	mV/V	2,0 (3,0)+/-0,1%
Excitation, dc or ac.	Volt	10 (15)
Safe service Load	%	150
Ultimate Load	%	300
Combined Error	%	<0,03
Repeatability	%	<0,02
Output at Zero Load	%	<2
Input Resistance	Ohms	750 +/-25
Output Resistance	Ohms	700 +/-3
Operational Temp.	*C	-20 to +80
Compensated temp.	*C	-10 to +40
Temp. Coeff. Of Zero	%/*C	<0,003
Temp. Coeff. Of Span	%/*C	<0,003
Creep in 30 minutes	%/*C	<0,02
Insulation	M ohms	>500 at 100V. dc

ELECTRICAL CONNECTION

CABLE	POLYURETHANE, Ø 5,4 mm,10 meter
+EXCITATION	RED
-EXCITATION	BLUE
+SIGNAL	GREEN
-SIGNAL	YELLOW

DAN-TRANSDUCER ApS

Fiskerengen 5, DK-3250 Gilleleje - Phone: +45 48 22 44 02 - Fax: +45 48 22 44 06
www.dan-transducer.com, E-mail: info@dan-transducer.com