

# DAN-TRANSDUCER ApS

S-TENSION LOAD CELLS IN SHEAR  
CAPACITIES: 250 KG TO 5000 KG

MODEL DT 8220



MODEL DT 8220

## COMPLETE SERIE OF LOAD CELLS FOR TENSION / COMPRESSION

- STAINLESS STEEL LOAD CELLS
- EYEBOLTS IN NICKELPLATED STEEL OR IN STAINLESS STEEL
- FULLY WELDED LOAD CELL UP TO IP 68
- 3000 DIVISIONS O.I.M.L. APPROVED
- EASY AND LOW COST INSTALATION
- MODEL DT 8220 CAN BE USED IN COMPRESSION AS WELL
- EXTENDED SERIE IN LOWER AND HIGHER CAPACITIES

**DAN-TRANSDUCER ApS**

Fiskerengen 5, DK-3250 Gilleleje - Phone: +45 48 22 44 02 - Fax: +45 48 22 44 06  
[www.dan-transducer.com](http://www.dan-transducer.com), E-mail: [info@dan-transducer.com](mailto:info@dan-transducer.com)

# DAN-TRANSDUCER ApS

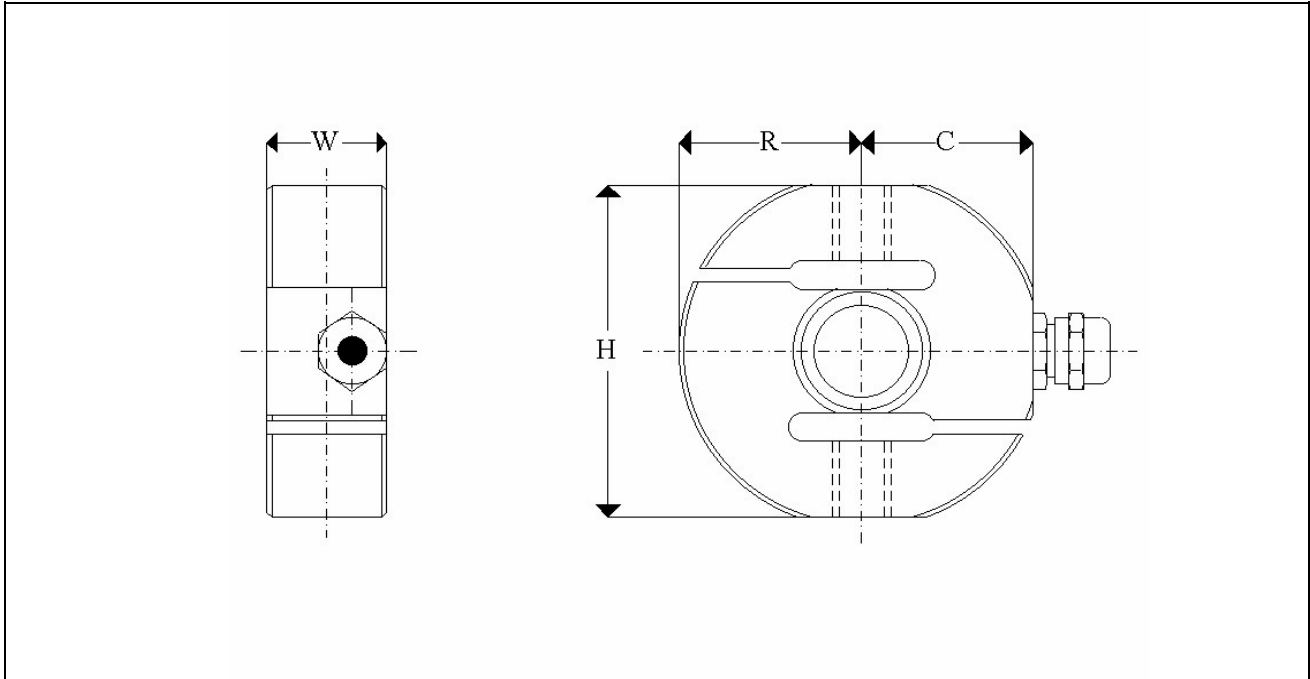

## DIMENSIONS

MODEL	RANGES	EXEC.	H	W	R	C	T	CABLE
8220	250 - 500 kg	WELDED	70	24,5	37,5	35	M12 x 1,75	5 M
8220	1000-2000 kg	WELDED	95	30	50	45	M20 x 1,5	5 M
8220	5000 kg	WELDED	120	40	62,5	57,5	M24 x 2	5 M

## SPECIFICATIONS

	UNITS	C3	C1
Standard load ranges	kg	500,1000,2000,5000	250,500,1000,2000,5000
Full Load Output	mV/V	2,0+/-0,1%	2,0+/-0,25%
Excitation, dc or ac	Volt	10(15)	10(15)
Safe service load	%	150	150
Ultimate Load	%	300	300
Combined Error	%	<0,02	<0,05
Repeatability	%	<0,01	<0,02
Min. division		Emax/10.000	Emax/5.000
Output at Zero Load	%	<+/-1	<+/-2
Input Resistance	Ohms	400+/-20	400+/-20
Output Resistance	Ohms	350+/-3	350+/-3
Operational Temp.	*C	-20 to +80	-20 to +80
Compensated Temp.	*C	-10 to +40	-10 to 40
Temp. Coeff. of Zero	%/*C	<0,002	<0,005
Temp. Coeff. of Span	%/*C	<0,001	<0,003
Creep in 4 hours	%	<0,025	<0,05
Insulation	M Ohms	>500 at 100V.dc	>500 at 0V. dc

## ELECTRICAL CONNECTION

CABLE	POLYURETHANE, Ø 5,4 mm
+EXCITATION	RED
-EXCITATION	BLUE
+SIGNAL	GREEN
-SIGNAL	YELLOW

## DAN-TRANSDUCER ApS

Fiskerengen 5, DK-3250 Gilleleje - Phone: +45 48 22 44 02 - Fax: +45 48 22 44 06  
[www.dan-transducer.com](http://www.dan-transducer.com), E-mail: [info@dan-transducer.com](mailto:info@dan-transducer.com)