

DAN-TRANSDUCER ApS

COMPRESSION LOAD CELL
CAPACITIES: 15 TONS TO 60 TONS

MODEL DT 740



MODEL DT 740

COMPLETE SERIE OF LOAD CELLS FOR TRUCK SCALES

- COMPRESSION LOAD CELL, SELF-CENTERING COLUMN
- 3000 DIVISIONS O.I.M.L. R60, CLASS C3.
- SIMPLE TO INSTALL
- ALL WELDED STAINLESS STEEL CONSTRUCTION, IP 68.
- PR-CORNER ADJUSTMENT OPTIMIZED FOR MULTICELL SYSTEM

DAN-TRANSDUCER ApS

Fiskerengen 5, DK-3250 Gilleleje - Phone: +45 48 22 44 02 - Fax: +45 48 22 44 06
www.dan-transducer.com, E-mail: info@dan-transducer.com

DAN-TRANSDUCER ApS

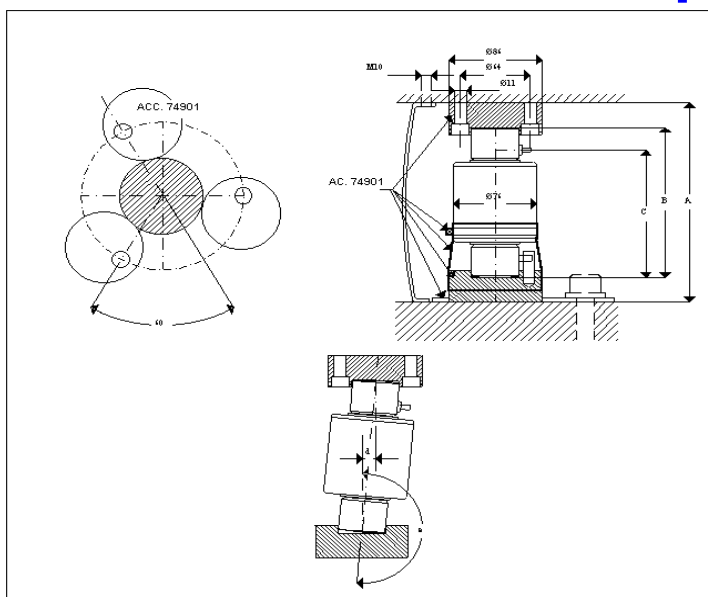

DIMENSIONS

	A	B	C	d. max	e. max	Ball R.	Weight
LOAD CELL							
DT 740, 15-40T	200	150	123	13	5	130-180	2-3 KG
DT 740, 60T	260	210	153	11	3	220	3,7 KG

SPECIFICATIONS

	UNITS	AMOUNT
Nominal capacities, (Ln)	TONS	15-20-30-40-60
Minimum division	VMIN.	1/10.000
Accuracy class	N, LC OIML	3000
Minimum dead load (EMIN)	% Ln	0
Service load	% Ln	120
Safe load limit	% Ln	150
Total error	% Cn	<+/-0,017
Repeatability	% Cn	<+/-0,015
Temperature effects: Zero	% Cn/5 K	<+/-0,001
Temperature effects: span	% Cn/5 K	<+/-0,006
Creep error (30 minutes)	% Cn	<+/-0,016
Temperature compensation	*C	-10 to +40
Temperature limits	*C	-30 to +70
Sensitivity (C)	MV/V	2+/-0,1%
Nominal input voltage	Volts	10
Maximum input voltage	Volts	15
Input impedance	Ohms	800+/-30
Output impedance	Ohms	700+/-3
No load output	% Cn	<+/-2
V.min.		E.max./7.500
Insulation resistance	M ohms	>500
Maximum deflection	Mm	< 0,6

ELECTRICAL CONNECTION

CABLE	PVC, Ø 6 mm; 20 meter
+EXCITATION	GREEN
-EXCITATION	BLACK
+SIGNAL	RED
-SIGNAL	WHITE
+ SENSE	BLUE
- SENSE	YELLOW

DAN-TRANSDUCER ApS

Fiskerengen 5, DK-3250 Gilleleje - Phone: +45 48 22 44 02 - Fax: +45 48 22 44 06
www.dan-transducer.com, E-mail: info@dan-transducer.com