

DAN-TRANSDUCER ApS

FORCE WASHER MODEL DT 1900
STANDARD CAPACITIES: From 1 Tons to 20 Tons



MODEL DT 1900

COMPLETE SERIE OF FORCE WASHERS

- **SERIE DT 1900 FORCE WASHERS FOR MANY APPLICATIONS.**
- **SUITABLE FOR METRIC OR IMPERIAL BOLTS.**
- **ROBUST CONSTRUCTION**
- **LOW PROFILE AND COMPACT.**
- **CAPACITIES: 1.000 KG TO 20.000 KG**
- **SEALED TO IP66**
- **LOW DEFLECTION**

DAN-TRANSDUCER ApS

Fiskerengen 5, DK-3250 Gilleleje - Phone: +45 48 22 44 02 - Fax: +45 48 22 44 06
www.dan-transducer.com, E-mail: info@dan-transducer.com

DAN-TRANSDUCER ApS

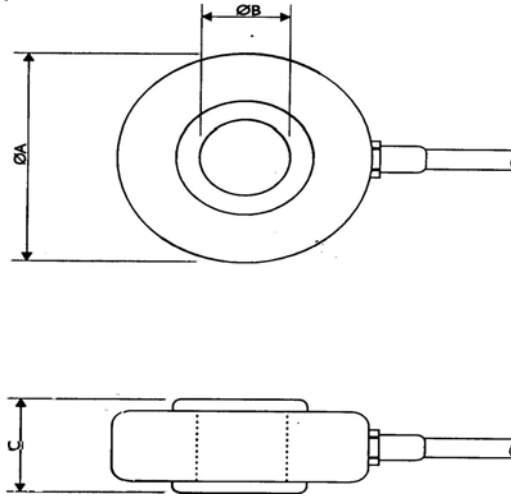

Capacity (kN)	Bolt Size	A	B	C
10	M6	18	6.1	12
20	M8	22	8.1	12
40	M10	28	10.2	12
80	M12	38	12.2	15
100	M16	42	16.3	20
120	M24	50	24.3	25
160	M30	60	30.5	30
200	M36	75	36.5	30

SPECIFICATIONS

	UNITS	AMOUNT
Capacities, E _{MAX}	T	1,2,4,8,12,16,20
Full load output	mV/V	1.0 nom
Zero load output	%	<±1.0
Excitation (Max)	V	10 (15)
Accuracy	%	<0.5
Repeatability	%	<±0,10
Input Resistance	Ω	750
Output Resistance	Ω	700
Compensated Temp. Range	°C	0 to +70
Operating Temp. Range	°C	-20 to +80
Temp. Coefficient on Zero	% Capacity/°C	<0.030
Temp. Coefficient on Span	% Capacity/°C	<0.0050
Safe Overload	%	150
Insulation	MΩ	>500
Environmental Protection		IP66

ELECTRICAL CONNECTION

CABLE	POLYURETHANE, Ø5,4 mm
+ EXCITATION	RED
- EXCITATION	BLUE
+ SIGNAL	GREEN
- SIGNAL	YELLOW

DAN-TRANSDUCER ApS

Fiskerengen 5, DK-3250 Gilleleje - Phone: +45 48 22 44 02 - Fax: +45 48 22 44 06
www.dan-transducer.com, E-mail: info@dan-transducer.com